



**Installation Manual and Information for
VMAC OEM Compressor Hose Connections**

**General Hose and Tube Packages for VR70
and VR130 Compressor Packages**

www.vmacair.com

Table of Contents

Table of Contents	1
General Information	3
Safety	4
Safety Precautions	5
Connecting the Hoses	7
JIC Fittings	7
Push-To-Connect Fittings	8
Hose Connections	8
Oil Lines	9
Optional Check Valve	10
Optional Thermostatic Valve	10
Pneumatic Control Lines	11
Systems with Remote Blowdown and Coalescing Filter	11
Systems with Integrated Blowdown and Coalescing Filter	12
Air Lines	13
Systems with Remote Blowdown and Coalescing Filter	14
Systems with Integrated Blowdown and Coalescing Filter	15
Hose Routing Overview	17

Changes and Revisions

Revision	Revision Details	Revised by	Checked by				Implemented
			Eng.		Tech.	Qual.	
			Mech.	Elec.			
A	ECN-19-213: Engineering Release	NDB	PID	N/A	DSB	A.M.	10 DEC 2020

Important Information

The information in this manual is intended for certified VMAC dealers who have been trained in installation and service procedures and/or for anyone with mechanical trade certification who have the tools and equipment to properly and safely perform the service. Do not attempt this service without the appropriate mechanical training, knowledge, and experience.

Follow all safety precautions for mechanical work. Any fabrication for correct fit in equipment must follow industry standard “best practices”.

Notice

Copyright © 2020 VMAC Global Technology Inc. All Rights Reserved. These materials are provided by VMAC for informational purposes only, without representation or warranty of any kind, and VMAC shall not be liable for errors or omissions with respect to the materials. The only warranties for VMAC products and services are those set forth in the express warranty statements accompanying such products and services, if any, and nothing herein shall be construed as constituting an additional warranty. Printing or copying of any page in this document in whole or in part is only permitted for personal use. All other use, copying or reproduction in both print and electronic form of any part of this document without the written consent of VMAC is prohibited. The information contained herein may be changed without prior notice.

Printed in Canada

General Information

Introduction

This manual provides installation instructions for the generic installation of hose connections for VMAC compressor systems. Read this manual prior to servicing or operating the compressor system.

Follow all safety precautions when servicing or operating the VMAC system.

Proper service and repair are important to the safety of the operator and the safe, reliable operation of the equipment. Always use genuine VMAC replacement parts.

The procedures described in this manual are the only approved methods of service and operation.

Ordering Parts

To order parts, contact the VMAC Inside Sales department. To assist in selecting the appropriate parts, please provide the VMAC compressor serial number, part number, description, and quantity. Contact VMAC Inside Sales by calling 1 (887) 912-6605 or by email to sales@vmacair.com.

Safety

Important Safety Notice



The information contained in this manual is based on sound engineering principles, research, extensive field experience and technical information. Information is constantly changing with the addition of new models, assemblies, service techniques and running OEM changes. If a discrepancy is found in this manual, contact the VMAC OEM department prior to initiating or proceeding with installation, service or repair. Current information may clarify the issue. Anyone with knowledge of such discrepancies, who proceeds to perform service and repair, assumes all risks.

Only proven service procedures are recommended. Anyone who departs from the specific instructions provided in this manual must first assure that their safety and that of others is not being compromised, and that there will be no adverse effects on the operational safety or performance of the equipment.

VMAC will not be held responsible for any liability, consequential damages, injuries, loss or damage to individuals or to equipment as a result of the failure of anyone to properly adhere to the procedures set out in this manual or standard safety practices. Safety should be the first consideration when performing any service operations. If there are any questions concerning the procedures in this manual, or more information is required, please contact VMAC OEM department prior to beginning repairs.

Safety Messages

This manual contains various warnings, cautions and notices that must be observed to reduce the risk of personal injury during installation, service or repair and the possibility that improper installation, service or repair may damage the equipment or render it unsafe.

	<p><i>This symbol is used to call attention to instructions concerning personal safety. Watch for this symbol; it points out important safety precautions, it means, "Attention, become alert! Your personal safety is involved". Read the message that follows and be aware of the possibility of personal injury or death. As it is impossible to warn of every conceivable hazard, common sense and industry standard safety practices must be observed.</i></p>
	<p><i>This symbol is used to call attention to instructions on a specific procedure that if not followed may damage or reduce the useful life of the compressor or other equipment.</i></p>
	<p><i>This symbol is used to call attention to additional instructions or special emphasis on a specific procedure.</i></p>

Safety Precautions



As it is impossible to warn of every possible hazard that may result from operating this system, common sense and industry standard safety practices must be observed.

Read this information before operating the compressor for the first time. Follow the information and procedures in this manual for operation, maintenance and repair. Observe the following items to reduce the chance of personal injury or equipment damage.

Proper service and repair are important to the safety of the service technician and the safe, reliable operation of the equipment. Always use genuine VMAC replacement parts.

The procedures described in this service manual are effective methods of service and repair. Some procedures may require the use of tools specially designed for a specific purpose. Anyone using a replacement part, service procedure or tool must first determine that neither their safety nor the safe operation of the equipment will be compromised by the replacement part, service procedure or tool selected.



Moving Parts Hazard

- Before performing service, disconnect the power source to prevent unexpected equipment start.
- Do not operate the system without guards in place. If the guards are damaged or missing, replace them before operating the equipment.





Burn Hazard

- The compressor system get very hot during operation, contact with the components or the oil can cause serious injury. Allow sufficient time for the system to cool prior to performing service.
- Never allow any part of your body to contact the compressor components until the system has cooled sufficiently.

	<p>Compressor Air and Oil Hazard</p> <ul style="list-style-type: none"> • The compressor system is under sufficient pressure that a leak could force the air/oil mixture through the skin directly into your bloodstream. This could cause serious injury or death. • Ensure the system is completely depressurized before attempting maintenance or repair. • Do not use compressed air to clean off clothing or skin, compressed air can penetrate the skin causing serious injury or death. • Do not move or service the system while it is pressurized or operating. • Components and hoses under pressure could separate suddenly and cause serious injury or death. If equipped, the air receiver tank must be drained prior to servicing the system. • Never adjust or attempt to make any repairs to the system while the engine is running. Components and hoses under pressure could fail and cause serious injury or death.
----------------------------------------------------------------------------------	-----------------------------------------------------------------------------------------------------------------------------------------------------------------------------------------------------------------------------------------------------------------------------------------------------------------------------------------------------------------------------------------------------------------------------------------------------------------------------------------------------------------------------------------------------------------------------------------------------------------------------------------------------------------------------------------------------------------------------------------------------------------------------------------------------------------------------------------------------------------------------------------------------------------------------------------------------------------------------------------------------------

	<p>Burst Hazard</p> <ul style="list-style-type: none"> • Serious injury or death may result from an air tank explosion. • Never exceed manufacturer's maximum air pressure rating. • Do not repair components, only replace with approved parts. • Do not tamper with, or disable factory safety equipment.
----------------------------------------------------------------------------------	--------------------------------------------------------------------------------------------------------------------------------------------------------------------------------------------------------------------------------------------------------------------------------------------------------------------------------------------------------------

  	<p>Personal Safety</p> <ul style="list-style-type: none"> • Vaporized oil is a respiratory hazard, do not breathe the compressor air. • Always use the appropriate personal protective equipment, particularly eye and hearing protection when operating air powered equipment.
---------------------------------------------------------------------------------------------------------------------------------------------------------------------------------------------------------------------------------------------------------	----------------------------------------------------------------------------------------------------------------------------------------------------------------------------------------------------------------------------------------------------------------------------------------------------------------

Connecting the Hoses



When routing hoses, ensure cap plugs are installed so that contaminants do not get in the line. Take care when routing hoses, as a hose failure may damage the compressor and/or cause injury.



All hoses, tubes and wires that are installed, rerouted or shifted during the installation must be secured so that they do not contact any hot, sharp or moving parts. Use rubber coated P-clips wherever possible. Follow the routing suggestions in this manual and cover all hoses with protective coating.

JIC Fittings



Do not overtighten JIC Hydraulic fittings. Overtightening may cause reduced life or permanent deformation of the sealing area of the fitting.



JIC type hydraulic fittings do not require sealing compound or teflon sealing tape. JIC fittings when properly tightened form a metal to metal seal. Adding sealing compound or teflon sealing tape may introduce gaps and prevent the formation of a seal.

- Spin-on the swivel nut by hand until it bottoms out; do not overtighten by hand.
- Using two appropriately sized wrenches, tighten the swivel using the Flats From Wrench Resistance (FFWR) method.

FFWR method:

1. At the bottom out position, mark a line across the two fittings
2. Note the fitting/hose size and tighten the fitting by the value indicated in the table below.
3. Turn the fitting by the number of flats indicated (1 flat = 1/6 revolution or 60° rotation) or until firm resistance is met.

Fitting (hose) size	Flats	Degrees rotation
#04 (1/4")	2	120°
#05 (5/16")	2	120°
#06 (3/8")	1-1/2	90°
#08 (1/2")	1-1/2	90°
#12 (3/4")	1-1/4	75°
#16 (1")	1	60°

Table 1 - FFWR Method Tightening Values

Push-To-Connect Fittings



The tube and fitting must have less than 0.5mm (1/64") of coaxial play in line with the tube in order to prevent the internal O-ring from wearing prematurely. Follow instructions below.

- Firmly push the tube fully into the fitting such that the internal collet fits inside the tube. A secondary push may be required so that it fully seats in the fitting as a false sense of restriction may occur. The collet can be pushed in to help ease installation.
- Slide the collet out, away from the body of the fitting to lock the tubing in place. A tool such as a flat head screwdriver may be required to pry the collet out enough such that there is less than 0.5mm (1/64") of coaxial play to prevent the internal O-ring from wearing prematurely.

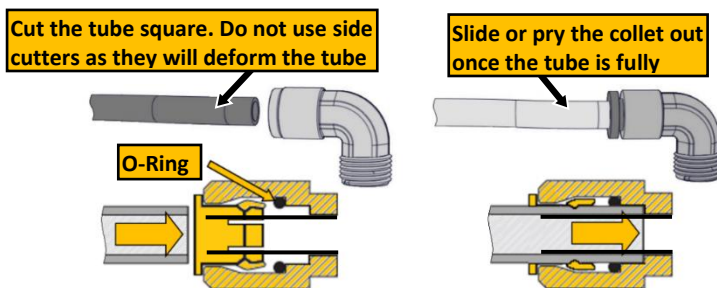

Figure 1 - Push-To-Connect Fittings

Hose Connections

Refer to the following sections for diagrams and further reference regarding the following connection line installations. For hose specification, please see the Hose Routing Overview section (pages 17-18).

	VMAC uses hoses and tubing that have been specifically specified for the application and may differ from standard hosing and tubing. For current and complete details on hose types and sizes, see VMAC Technical Support Bulletin regarding VMAC hoses on the online knowledge base: https://kb.vmacair.com/help/required-vmac-hoses
	Hoses for VMAC systems require a temperature rating of -40°C to 150°C (-40°F to 302°F) or greater. Pressure rating must be a minimum of 300 psi operating (working) pressure. Lines for compressed air vary in size depending on air output. For VR90 and lower air flow systems, 3/8" hose with #12 JIC connections are used. For VR130 and larger systems, 1" hose with #16 JIC connections are used.
	VMAC air compressor systems require the use of hoses with special liners to stand up to the unique properties of VMAC compressor oil and the high heat that our compressors generate. Examples: Aeroquip- AQP™, Parker-PKR®, and Gates-GTS (CPE)™.

Oil Lines

- Connect the oil line from the separator tank (hot oil) located at the bottom of the oil separator tank to the “Oil Flow In” fitting located on the oil cooler (Figure 2). Use a second wrench to support the fitting on the component and prevent it from spinning when tightening. The recommended hose size is #8 (1/2”) hose.

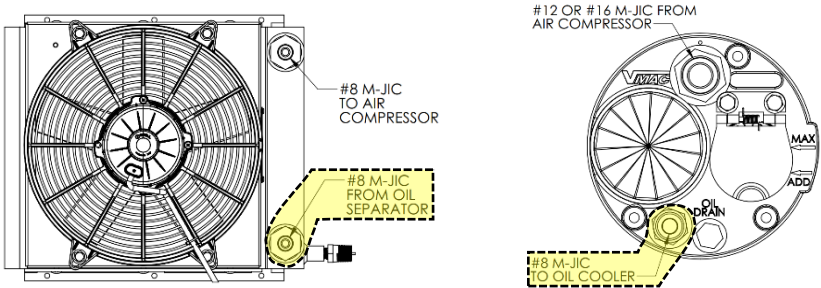

Figure 2 – Hot Oil Line Connection

- Connect the oil return line (cooled oil) located on the bottom left of the compressor to the “Oil Flow Out” fitting of the oil cooler (Figure 3). Use a second wrench to support the fitting on the component and prevent it from spinning when tightening. The recommended hose size is #8 (1/2”) hose.

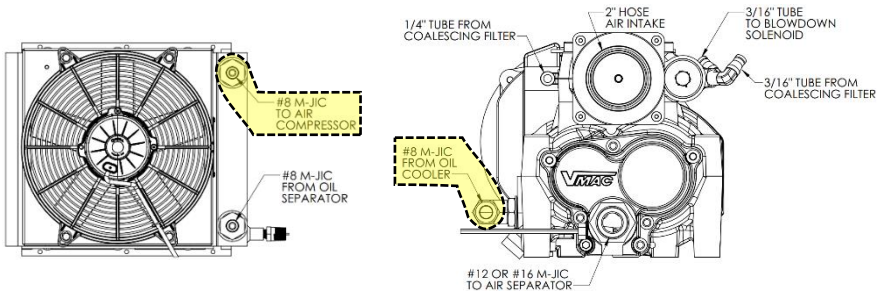

Figure 3 – Cold Oil Line Connection

- If using a liquid to oil cooler, attach the connections for cross-flow cooling so that the flow is in opposite directions as indicated in Figure 4 below.

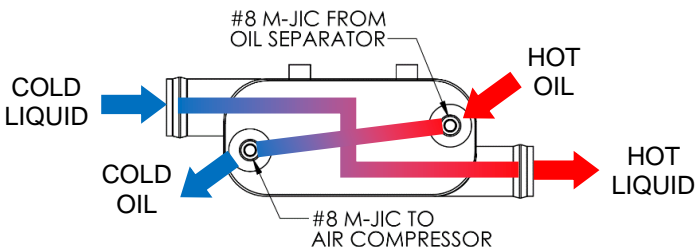
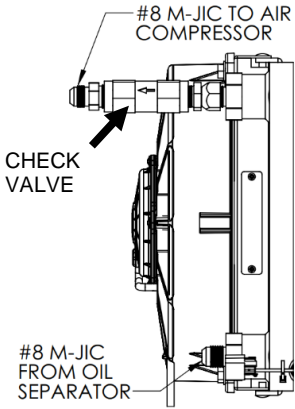

Figure 4 - Liquid to Oil Cooler Cross-Flow

Optional Check Valve

- If using the optional check valve package, the “Oil Flow Out” fitting is located after the check valve.



Liquid to Air Cooler

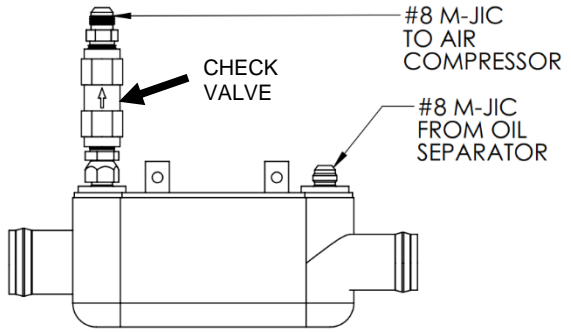

Liquid to Liquid Cooler

Figure 5 - Optional Check Valve

Optional Thermostatic Valve

- If using the optional thermostatic valve package, the “Oil Flow Out” fitting is located after the check valve. The “Oil Flow In” fitting is located on the thermostatic valve.

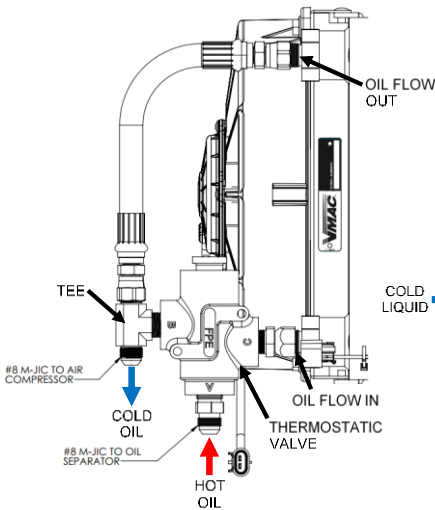

Liquid to Air Cooler

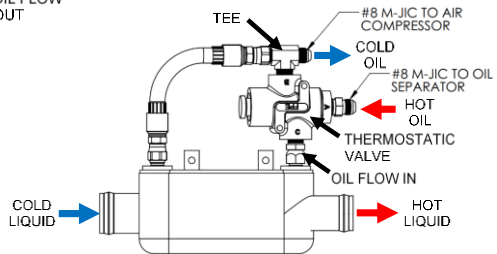

Liquid to Liquid Cooler

Figure 6 - Optional Thermostatic Valve

Pneumatic Control Lines

Systems with Remote Blowdown and Coalescing Filter

- Connect the scavenge line from the top left side of the air compressor to the center top of the coalescing filter (Figure 7 – dotted line). The tube size and type is 1/4" PTFE tube with specialized wall thickness and formula to withstand the high pressures, temperatures, and oil used.
- Connect the pressure signal line from the front top right side of the air compressor to the top front right of the coalescing filter (Figure 7 – dashed line). The tube size and type is 3/16" PTFE tube with specialized wall thickness and formula to withstand the high pressures, temperatures, and oil used.

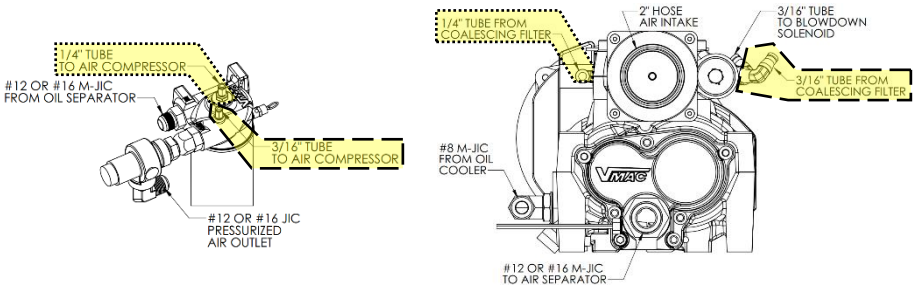

Figure 7 – Scavenge and Pressure Signal Line Connections

- Connect the blowdown line from the rear top right side of the air compressor to the left side of the blowdown solenoid (Figure 8). The tube size and type is 3/16" PTFE tube with specialized wall thickness and formula to withstand the high pressures, temperatures, and oil used.

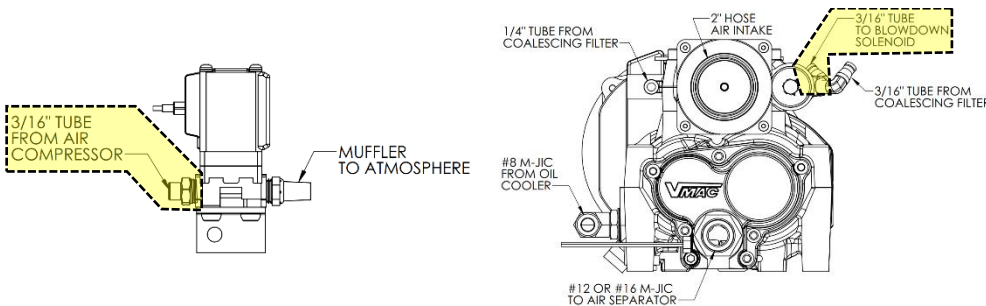

Figure 8 – Blowdown Line Connection

Systems with Integrated Blowdown and Coalescing Filter

- Connect the scavenge line from the top left side of the air compressor to the center bottom of the separation tank (Figure 9 – dotted line). The tube size and type is 1/4" PTFE tube with specialized wall thickness and formula to withstand the high pressures, temperatures, and oil used.
- Connect the pressure signal line from the front top right side of the air compressor to the center top of the separation tank (Figure 9 – dashed line). The tube size and type is 3/16" PTFE tube with specialized wall thickness and formula to withstand the high pressures, temperatures, and oil used.

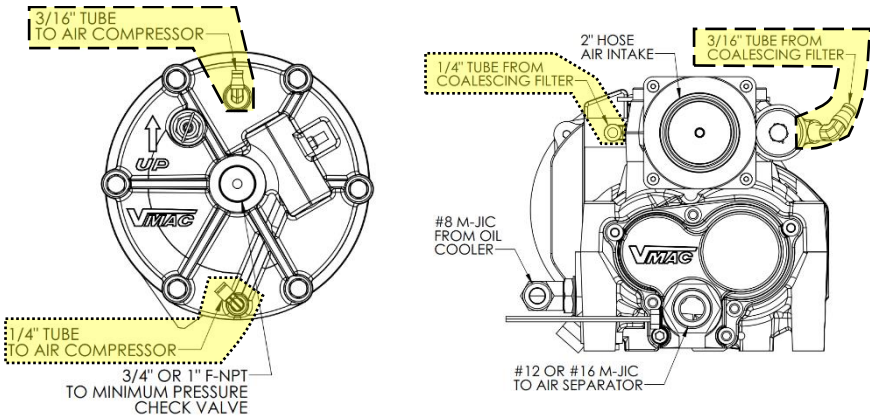

Figure 9 – Scavenge and Pressure Signal Line Connections

Air Lines

- Option 1: If installing the local air intake filter, install the filter to the compressor air intake located at the top rear of the air compressor (Figure 10).
- Option 2: If installing the remote air intake filter package, slip the hose over the compressor air intake located at the top rear of the air compressor (Figure 10) and tighten the hose clamps.

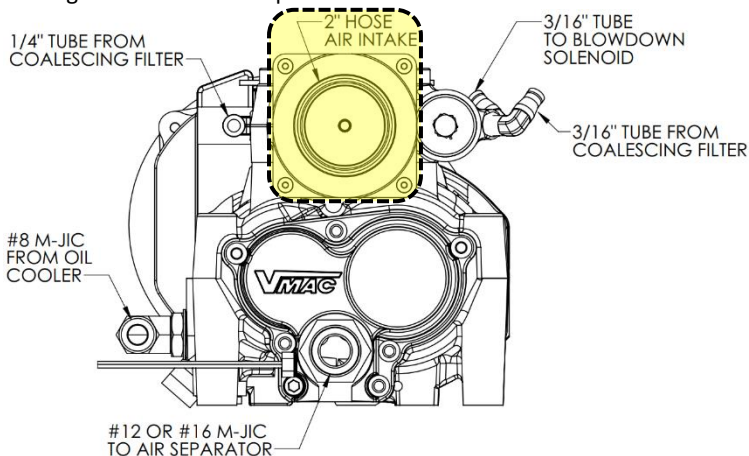

Figure 10 – Air Intake Filter Connection

- Connect the air hose from the bottom rear of the compressor to the fitting located at the top inlet side of the oil separator tank (same side as sight glass) (Figure 11). Use a second wrench to support the fitting on the component and prevent it from spinning when tightening. The recommended hose size is #12 (3/4") hose for VR90 and lower air flow systems and #16 (1") hose for VR130 and higher air flow systems.

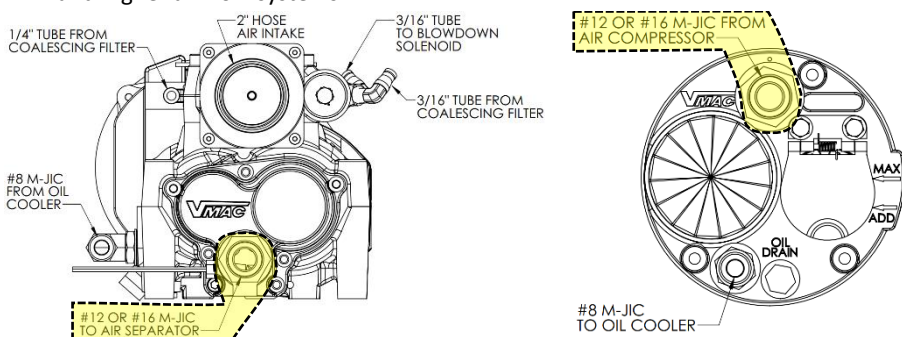

Figure 11 – Compressor Air Line Connection

Systems with Remote Blowdown and Coalescing Filter

- Connect the air hose from the center outlet side of the oil separator tank to the left fitting on the coalescing filter labeled “IN” (Figure 12). Use a second wrench to support the fitting on the component and prevent it from spinning when tightening. The recommended hose size is #12 (3/4”) hose for VR90 and lower air flow systems and #16 (1”) hose for VR130 and higher air flow systems.

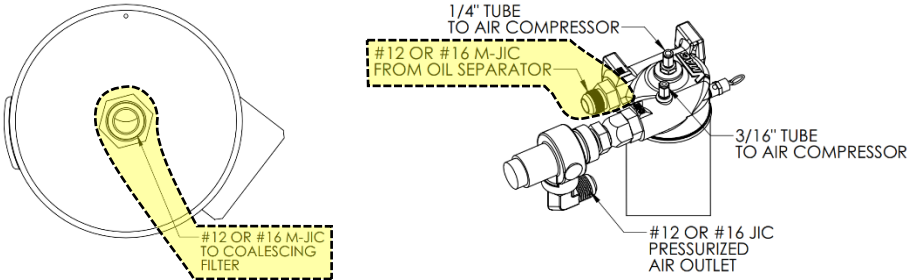

Figure 12 – Oil Separator Air Line Connection

- The end user may choose and install their preferred outlet fitting onto the pressurised air outlet fitting on the coalescing filter (Figure 13) . The outlet is a female NPT located on the minimum pressure check valve. VMAC recommends attaching a MNPT to MJIC to connect to a hose with JIC swivel fittings. VR90 and lower air flow units use #12/ 3/4” sized fittings and VR130 and larger air flow units use #16/1” sized fittings.

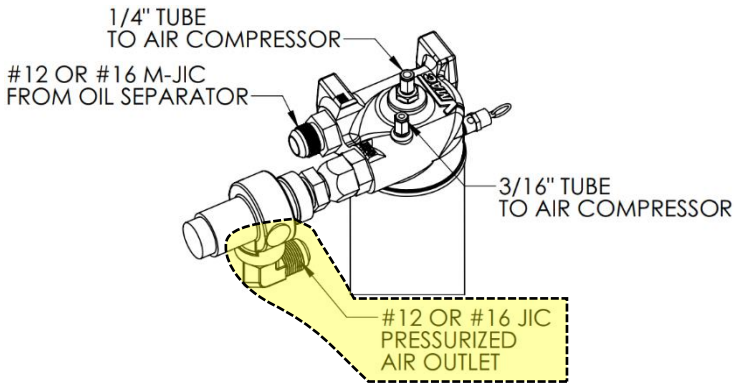

Figure 13 – Air Outlet

Systems with Integrated Blowdown and Coalescing Filter

- Connect the air hose from the center outlet side of the oil separator tank to the bottom female fitting of the minimum pressure check valve. Either a NPT bushing may be used or a hose with fittings of choice (Figure 14). Use a second wrench to support the fitting on the component and prevent it from spinning when tightening a hose if used. The recommended hose size is #12 (3/4") hose for VR90 and lower air flow systems and #16 (1") hose for VR130 and higher air flow systems.

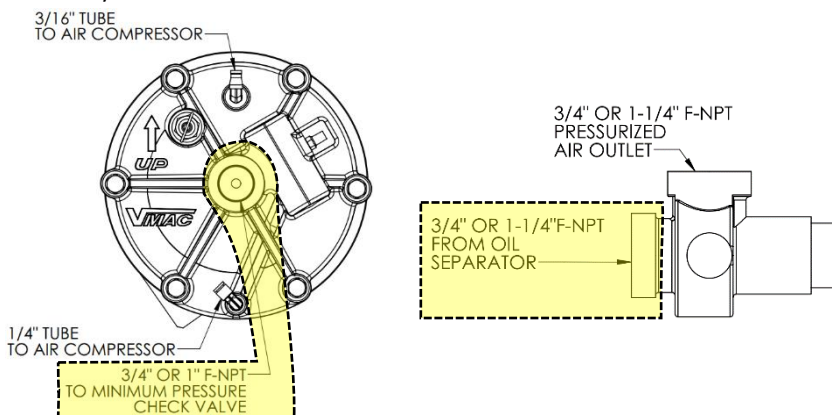

Figure 14 – Oil Separator Air Line Connection

- The end user may choose and install their preferred outlet fitting onto the pressurised air outlet fitting on the side of the minimum pressure check valve (Figure 15). The outlet is a female NPT, VMAC recommends attaching a MNPT to MJIC to connect to a hose with JIC swivel fittings. VR90 and lower air flow units use #12/ 3/4" sized fittings and VR130 and larger air flow units use #16/1" sized fittings.

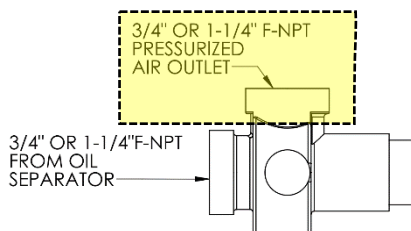

Figure 15 – Air Outlet

- Optional: The minimum pressure check valve (MPCV) can be relocated at the end user's discretion at any position downstream from the "OUT" port of the coalescer filter should fitment require it. The MPCV comes loose with the system. When relocating, the NPT pipe nipple should be replaced with a M-NPT to M-JIC on MPCV, and a M-NPT to M-JIC on the separation tank and connected using an appropriately sized hose with F-JIC swivels. See page 17 for detailed size requirements.

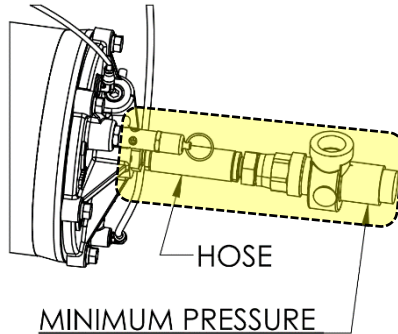

Figure 16 – Minimum Pressure Check Valve

Hose Routing Overview

Component	Component Fitting	Hose Fitting	Hose Size and type	Hose Fitting	Component Fitting	Component	Hose Function/contents	Diagram Assignment
Optional	Optional Air Intake Package				2" Slip-On Hose Adaptor	Air Compressor	Filtered Intake Air	1
Air Compressor	#12 M-JIC #16 M-JIC ³	#12 F-JIC #16 F-JIC ³	3/4" ^{1,2} 1" ^{1,2,3}	#12 F-JIC #16 F-JIC ³	#12 M-JIC #16 M-JIC ³	Oil Separator	Compressed Air/Oil Discharge	2
Oil Separator	#8 M-JIC	#8 F-JIC	1/2" ^{1,2}	#8 F-JIC	#8 M-JIC	Oil Cooler	Hot Filtered Oil	3
Oil Cooler	#8 M-JIC	#8 F-JIC	1/2" ^{1,2}	#8 F-JIC	#8 M-JIC	Air Compressor	Cold Filtered Oil	4
Air Compressor	1/4" PTC	-	1/4" PTFE Tube ²	-	1/4" PTC	Coalescing Filter	Scavenged Oil Return	5
Air Compressor	3/16" PTC	-	3/16" PTFE Tube ²	-	3/16" PTC	Coalescing Filter	Dry Compressed Air System Pressure Signal	6
Air Compressor	3/16" PTC	-	3/16" PTFE Tube ²	-	3/16" PTC	Blowdown Solenoid	Dry Compressed Air System Pressure	7
Oil Separator	#12 M-JIC #16 M-JIC ³	#12 F-JIC #16 F-JIC ³	3/4" ^{1,2} 1" ^{1,2,3}	#12 F-JIC #16 F-JIC ³	#12 M-JIC #16 M-JIC ³	Coalescing Filter	Compressed Air System Pressure with Oil Mist	8
Minimum Pressure Check Valve	#12 M-JIC	#12 F-JIC	3/4" ^{1,2}	End User Choice			Dry Compressed Air to Point of Use	9

Table 2 - Hose and Fitting Connections

All connections listed above are available through VMAC. Check package lists for components included in your system.

- 1- Temperature rating needs to be -40°C to 150°C (-40°F to 302°F) or greater. Pressure rating must be a minimum of 300 psi operating (working) pressure. Hoses require special liners for heat and oil compatibility (AQP or equivalent liner).
- 2- For current and complete details on hose types and sizes, see VMAC Technical Support Bulletin regarding required VMAC hoses on the online knowledge base: <https://kb.vmacair.com/help/required-vmac-hoses>
- 3- 3/4" hose with #12 JIC connections for VR90 and lower air flow systems, 1" with #16 JIC connections for VR130 and larger systems.

VMAC – Vehicle Mounted Air Compressors

VMAC Technical Support: 888-2412289

VMAC Knowledge Base: <https://kb.vmacair.com>

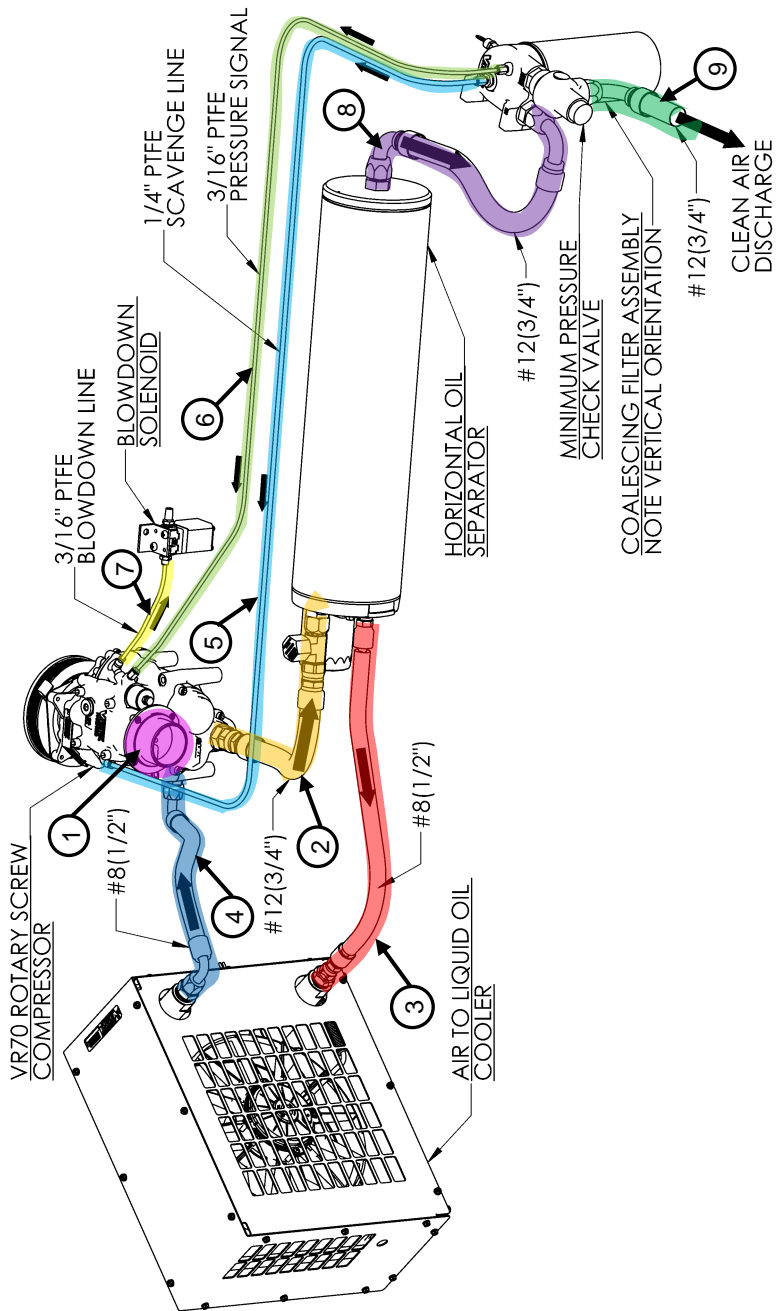

Figure 17 - Hose Routing

(VR70 with remote blowdown and coalescing filter, and air to oil cooler version shown)

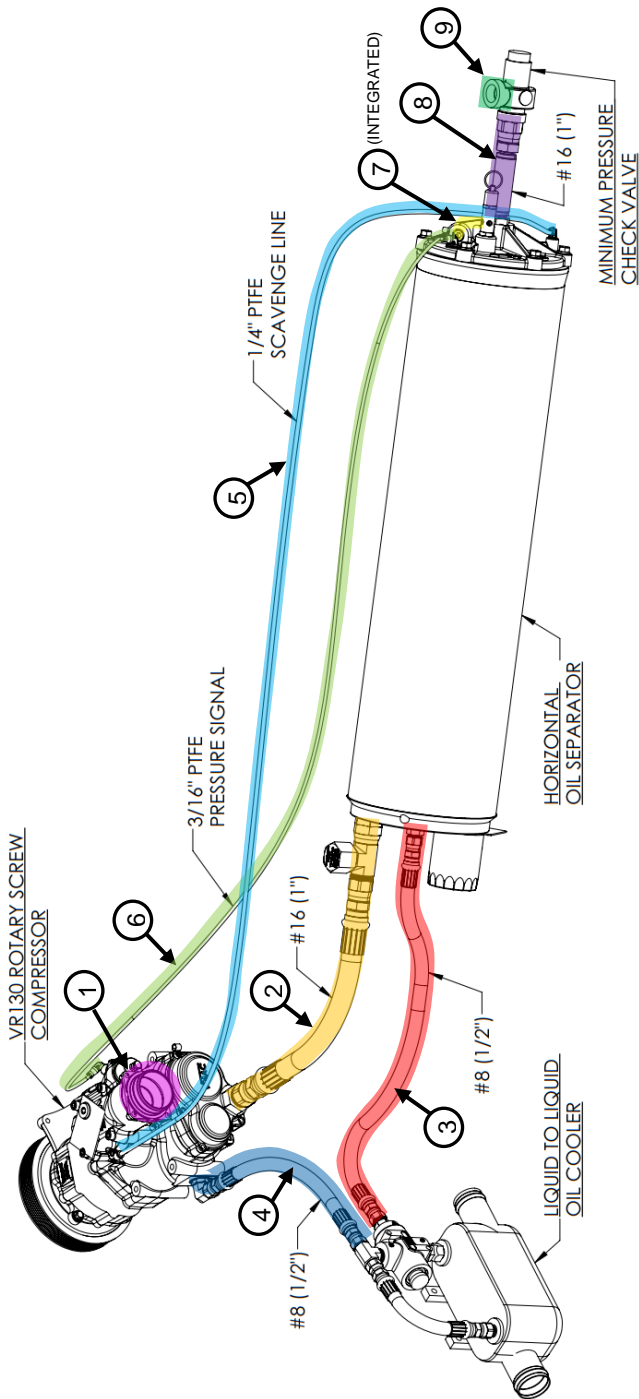

Figure 18 - Hose Routing

(VR130 with integrated blowdown and coalescing filter, and liquid to oil cooler version shown)

VMAC – Vehicle Mounted Air Compressors

VMAC Technical Support: 888-2412289

VMAC Knowledge Base: <https://kb.vmacair.com>

This page intentionally left blank

This page intentionally left blank

Manufactured by



888-241-2289



877-740-3202



www.vmacair.com



tech@vmacair.com



warranty@vmacair.com



www.kb.vmacair.com



1333 Kipp Road, Nanaimo, B.C., V9X 1R3 Canada